

SANITARY BALL VALVE

316L STAINLESS — TRI-CLAMP / WELD END

The Caspian Edge sanitary ball valve is a two-piece full-bore valve designed for hygienic process applications in food, dairy, beverage, pharmaceutical and biotech industries. Featuring a cavity-free body with floating ball and PTFE seats, it provides bubble-tight bi-directional shut-off with minimal flow resistance. All product-contact surfaces in 316L stainless steel and finished to Ra ≤ 0.8 µm standard (electropolished options available to Ra ≤ 0.38 µm for ASME BPE compliance).

MATERIAL	SIZE RANGE	PRESSURE	TEMPERATURE	CONNECTION	STANDARD
316L SS	DN15 – DN100	PN10 (10 bar)	-29 to +180°C	Tri-Clamp	3-A / ASME BPE

TECHNICAL DRAWING

DWG: CE-BV-001

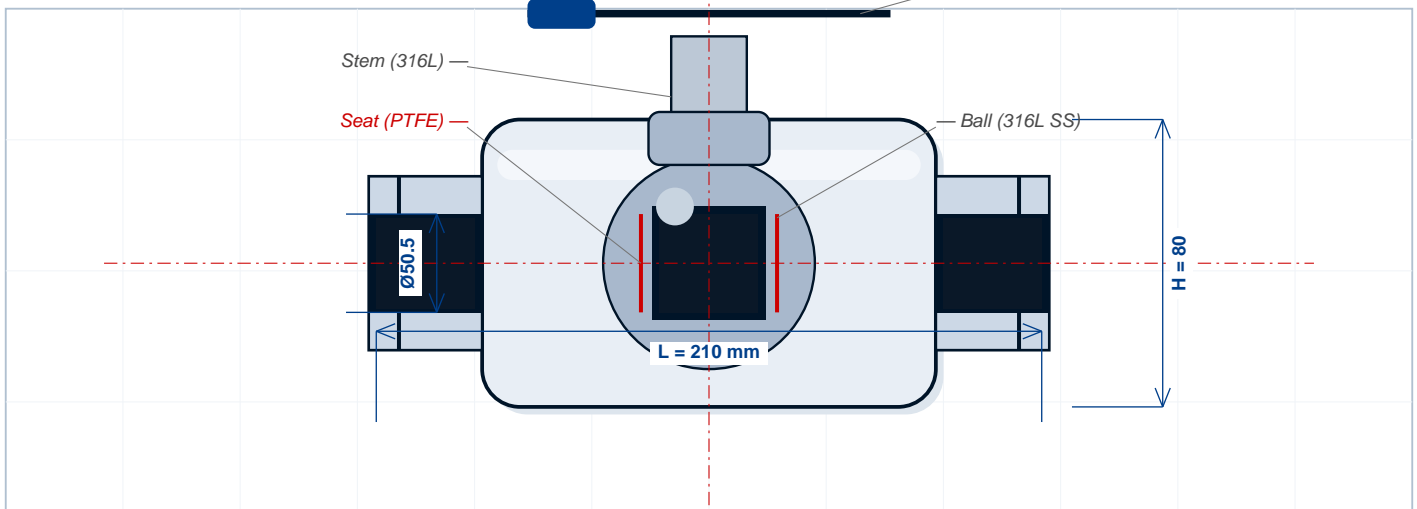

FRONT ELEVATION VIEW — 2" SANITARY BALL VALVE

Two-piece design · Full bore · Floating ball · Shown in OPEN position

CASPIAN EDGE INC. NORTH YORK, ON, CANADA	
DWG NO: CE-BV-001	SCALE: NTS
UNIT: mm	VIEW: FRONT ELEVATION

IN THIS DATASHEET

- PAGE 1** Technical drawing with dimensions and component callouts
- PAGE 2** Full technical specifications, materials and pressure-temperature data
- PAGE 3** Standards compliance, certifications and documentation
- PAGE 4** Applications, installation, maintenance and RFQ form

SANITARY BALL VALVE

316L STAINLESS — TRI-CLAMP / WELD END

DESIGN SPECIFICATIONS

SECTION 1

Design Type	Two-piece full-bore
Body Configuration	Cavity-free hygienic
Ball Type	Floating ball
Bore Style	Full bore (port = nominal)
End Connection	Tri-Clamp DIN 32676
Mounting	In-line, any orientation
Sealing System	PTFE seats + O-ring backup
Actuation	Manual / Pneumatic / Electric

OPERATING CONDITIONS

SECTION 2

PRESSURE RATING		TEMPERATURE RANGE	
Max Working Pressure	10 bar	PTFE Seat	-29 to +180 °C
Max Test Pressure	15 bar	EPDM O-Ring	-40 to +150 °C
Min Vacuum	-0.95 bar	Silicone	-50 to +200 °C
Pressure Class	PN10 / 150 psi	Viton (FKM)	-20 to +200 °C

PRESSURE-TEMPERATURE RATING CHART

SECTION 3

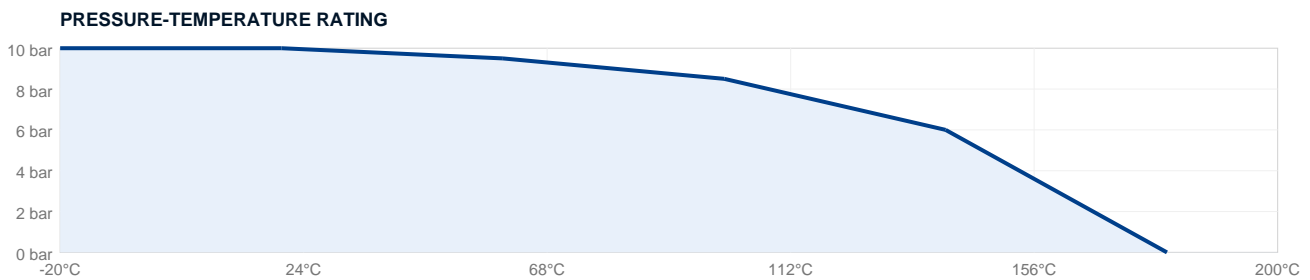

SURFACE FINISH OPTIONS

SECTION 4

DESIGNATION	RA (MM)	RA (MIN)	METHOD	APPLICATION
Standard	≤ 0.8	≤ 32	Mechanical polish	Food, dairy, beverage
Premium	≤ 0.5	≤ 20	Mech. polish + buff	Pharmaceutical
EP (BPE SF4)	≤ 0.38	≤ 15	Electropolish	Biotech, high-purity
Mirror	≤ 0.25	≤ 10	EP + final buff	Critical bioprocess

SANITARY BALL VALVE

316L STAINLESS — TRI-CLAMP / WELD END

MATERIALS OF CONSTRUCTION

SECTION 5

PART	STANDARD	OPTIONAL	SPEC
Body	316L SS	304/904L	ASTM A479
Ball	316L SS	904L/Hastelloy	ASTM A479
Stem	316L SS	17-4 PH	ASTM A479
Seat	PTFE	TFM/PEEK	FDA 21 CFR 177
Body Seal	EPDM	Silicone/PTFE	FDA 21 CFR 177
Stem Seal	PTFE V-Ring	Graphite	FDA
Handle	304 SS	316L SS	ASTM A276
Fasteners	A2-70 SS	A4-80 SS	ISO 3506

316L CHEMICAL COMPOSITION

SECTION 6

ELEMENT	SYMBOL	MIN %	MAX %	FUNCTION
Chromium	Cr	16.0	18.0	Corrosion resistance
Nickel	Ni	10.0	14.0	Ductility, toughness
Molybdenum	Mo	2.0	3.0	Pitting resistance
Carbon	C	—	0.03	Low carbon (L grade)
Manganese	Mn	—	2.0	Deoxidizer
Silicon	Si	—	0.75	Deoxidizer
Phosphorus	P	—	0.045	Impurity (limit)
Sulfur	S	—	0.030	Impurity (limit)

SIZE CHART & DIMENSIONS

SECTION 7

NOM.	DN	OD (MM)	L (MM)	H (MM)	CV	WEIGHT (KG)
½"	15	50.5	140	64	8	0.6
¾"	20	50.5	140	64	12	0.7
1"	25	50.5	160	70	25	0.9
1½"	38	64.0	175	74	60	1.4
2"	50	77.5	210	80	110	2.1
2½"	63	91.0	238	92	170	3.2
3"	76	104.0	260	105	280	4.8
4"	100	119.0	290	125	480	7.2

STANDARDS & CERTIFICATIONS

SECTION 8

STANDARD	DESCRIPTION	STATUS
3-A 74-07	Sanitary fittings for milk products	Compliant
ASME BPE-2022	Bioprocessing Equipment	Compliant (option)
ISO 2852:1993	Stainless steel clamp couplings	Compliant
DIN 32676	Tri-clamp connection dimensions	Compliant
FDA 21 CFR 177.2600	Rubber for food contact	Compliant
EC 1831/2003	Food contact materials	Compliant

SANITARY BALL VALVE

316L STAINLESS — TRI-CLAMP / WELD END

TYPICAL APPLICATIONS

SECTION 9

FOOD & BEVERAGE

- Filling line shut-off
- Product transfer lines
- CIP/SIP circuits
- Storage tank outlets
- Sampling stations
- Mixing & blending

DAIRY

- Pasteurization circuits
- Cheese processing
- Yogurt production
- Milk separators
- Cream lines
- 3-A compliant systems

PHARMA & BIOTECH

- WFI distribution
- Purified water systems
- API manufacturing
- Bioreactor connections
- Sterile filling
- Process skids

INSTALLATION GUIDELINES

SECTION 10

Caspian Edge sanitary valves are designed for in-line installation in any orientation. Follow these guidelines: **1. Pipe Preparation:** Ensure pipe ends are clean, deburred and free from contamination. Pipe OD must match valve ferrule OD specification. **2. Tri-Clamp Assembly:** Insert gasket between flanges. Position tri-clamp evenly and tighten gradually using torque sequence. Recommended torque: 5–7 N·m. **3. Flow Direction:** Most valves are bi-directional. Check valves and certain butterfly valves require specific orientation — refer to flow arrow on body. **4. Actuator Mounting:** Pneumatic actuator field-installable using ISO 5211 pattern. Air supply: 5–7 bar clean, dry, filtered air. **5. Commissioning:** Cycle valve 3–5 times before initial use. Verify no leakage at static pressure test (1.5x working pressure for 5 minutes).

MAINTENANCE SCHEDULE

SECTION 11

INTERVAL	ACTION	NOTES
Daily	Visual inspection	Check for leaks, unusual sounds
Weekly	Cycle test	Manual operation, verify smooth action
Monthly	Tri-clamp torque check	Re-tighten if loose, inspect gaskets
6 Months	Seal inspection	Replace seals if visible wear
Annually	Full overhaul	Disassemble, inspect, replace all seals
As needed	CIP/SIP integration check	Verify CIP coverage at valve cavity

REQUEST A TECHNICAL QUOTATION

Send your specifications and we will respond with detailed pricing, lead time and documentation.

INCLUDE IN YOUR RFQ:

Quantity · Size (DN) · Material grade · Seal material · Surface finish · Required certifications · Delivery date

[SUBMIT RFQ →](#)
caspiannedge.com/rfq